

WLS-IFC

USB-to-Wireless Interface

User's Guide

Trademark and Copyright Information

Measurement Computing Corporation, InstaCal, Universal Library, and the Measurement Computing logo are either trademarks or registered trademarks of Measurement Computing Corporation. Refer to the Copyrights & Trademarks section on mccdaq.com/legal for more information about Measurement Computing trademarks. Other product and company names mentioned herein are trademarks or trade names of their respective companies.

© 2014 Measurement Computing Corporation. All rights reserved. No part of this publication may be reproduced, stored in a retrieval system, or transmitted, in any form by any means, electronic, mechanical, by photocopying, recording, or otherwise without the prior written permission of Measurement Computing Corporation.

Notice

Measurement Computing Corporation does not authorize any Measurement Computing Corporation product for use in life support systems and/or devices without prior written consent from Measurement Computing Corporation. Life support devices/systems are devices or systems that, a) are intended for surgical implantation into the body, or b) support or sustain life and whose failure to perform can be reasonably expected to result in injury. Measurement Computing Corporation products are not designed with the components required, and are not subject to the testing required to ensure a level of reliability suitable for the treatment and diagnosis of people.

Table of Contents

Preface	
About this User's Guide	4
Conventions in this user's guide	4
Where to find more information	4
Chapter 1	
Introducing the WLS-IFC	5
Overview: WLS-IFC features	5
WLS-IFC block diagram	5
Chapter 2	
Installing the WLS-IFC	6
What comes with your WLS-IFC shipment?	6
Hardware	6
Software	6
Documentation	6
Unpacking the WLS-IFC	6
Installing the software	6
Installing the hardware	6
Configuring the network parameters	7
Restoring factory default settings	8
Chapter 3	
Functional Details	9
External components	9
Status LEDs	9
Power LED	10
USB connector	10
Chapter 4	
Specifications	11
Wireless communications	11
Memory	11
Microcontroller	11
USB +5V voltage	12
Power	12
USB specifications	12
Environmental	12
Mechanical	12
LED configuration	13
Declaration of Conformity	14

About this User's Guide

This user's guide describes the Measurement Computing WLS-IFC data acquisition interface device and lists device specifications.

Conventions in this user's guide

For more information

Text presented in a box signifies additional information related to the subject matter.

Caution! Shaded caution statements present information to help you avoid injuring yourself and others, damaging your hardware, or losing your data.

bold text **Bold** text is used for the names of objects on a screen, such as buttons, text boxes, and check boxes.

italic text *Italic* text is used for the names of manuals and help topic titles, and to emphasize a word or phrase.

Where to find more information

Additional information about WLS-IFC hardware is available on our website at www.mccdaq.com. You can also contact Measurement Computing Corporation with specific questions.

- Knowledgebase: kb.mccdaq.com
- Phone: 508-946-5100 and follow the instructions for reaching Tech Support
- Fax: 508-946-9500 to the attention of Tech Support
- Email: techsupport@mccdaq.com

Introducing the WLS-IFC

Overview: WLS-IFC features

The WLS-IFC is a USB-to-wireless interface module that is supported under popular Microsoft® Windows® operating systems. The WLS-IFC is fully compatible with both USB 1.1 and USB 2.0 ports.

The WLS-IFC device operates as the interface between a computer and one or more remote WLS-Series devices. The remote devices can be located up to 150 feet (50 meters) indoors, or up to ½ mile (750 m) outdoors from the WLS-IFC.

You configure the network parameters required for communication with remote devices. All parameters are software selectable. Only devices with the same parameter settings can communicate with each other. Once you configure the WLS-IFC to communicate with remote devices, you can connect it to different computers without having to configure the network parameters.

The WLS-IFC has LEDs that indicate the status of communication over the wireless link. An LED bar graph shows the fade margin of signals received by the WLS-IFC.

The WLS-IFC is a standalone plug-and-play device which draws power through the USB cable. No external power is required. All configurable options are software programmable.

WLS-IFC block diagram

WLS-IFC functions are illustrated in the block diagram shown here. The diagram shows the WLS-IFC communicating with three remote WLS devices. There is no limit to the number of WLS devices that the WLS-IFC can communicate with.

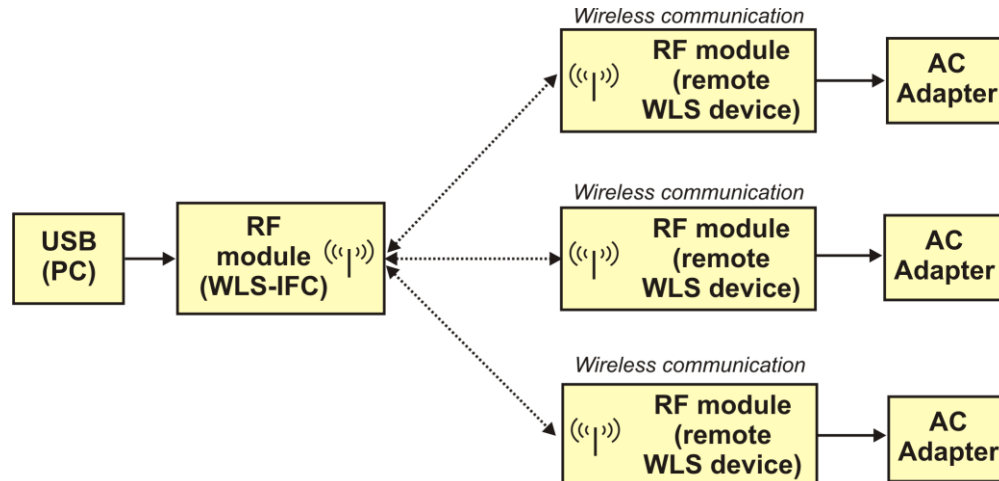

Figure 1. WLS-IFC functional block diagram

Installing the WLS-IFC

What comes with your WLS-IFC shipment?

The following items are shipped with the WLS-IFC.

Hardware

- WLS-IFC
- USB cable (2 meter length)

Software

- MCC DAQ Software CD

Documentation

- MCC DAQ Software Quick Start Guide

This booklet provides an overview of the MCC DAQ software you received with the device, and includes information about installing the software. Please read this booklet completely before installing any software or hardware.

Unpacking the WLS-IFC

As with any electronic device, you should take care while handling to avoid damage from static electricity. Before removing the device from its packaging, ground yourself using a wrist strap or by simply touching the computer chassis or other grounded object to eliminate any stored static charge.

If any components are missing or damaged, contact us immediately using one of the following methods:

- Knowledgebase: kb.mccdaq.com
- Phone: 508-946-5100 and follow the instructions for reaching Tech Support
- Fax: 508-946-9500 to the attention of Tech Support
- Email: techsupport@mccdaq.com

For international customers, contact your local distributor. Refer to the International Distributors section on our website at www.mccdaq.com/International.

Installing the software

Refer to the *Quick Start Guide* for instructions on installing the software on the MCC DAQ CD. This booklet is available in PDF at www.mccdaq.com/PDFmanuals/DAQ-Software-Quick-Start.pdf.

Installing the hardware

Install the MCC DAQ software before you install the WLS-IFC

The driver needed to run your board is installed with the MCC DAQ software. Therefore, you need to install the MCC DAQ software before you install your board. Refer to the *Quick Start Guide* for instructions on installing the software.

To connect the WLS-IFC to your system, do the following:

1. Turn your computer on, and connect the USB cable to a USB port on your computer or to an external USB hub connected to your computer. The USB cable provides power and communication to the WLS-IFC.

Always connect an external hub to its power supply

If you are using a hybrid hub (one that can operate in either self-powered or bus-powered mode), always connect it to its external power supply.

If you use a hub of this type without connecting to external power, communication errors may occur that could result in corrupt configuration information on your wireless device. You can restore the factory default configuration settings with InstaCal.

When you connect the WLS-IFC for the first time, a notification message opens as the WLS-IFC is detected. After your system detects new hardware, the **Found New Hardware Wizard** opens and prompts you to respond to the question "Can Windows connect to Windows Update to search for software?"

2. Click on the **No, not this time** option, and then click on the **Next** button.

The next dialog prompts you for the location of the software required to run the new hardware.

3. Keep the default selection "Install the software automatically" and then click on the **Next** button.

The wizard locates and installs the software on your computer for the WLS-IFC. A dialog appears when the wizard completes the installation.

4. Click on the **Finish** button to exit the **Found New Hardware Wizard**.

A dialog box opens when the hardware is installed and ready to use. Both the **Power LED** and the **USB Activity LED** should blink, and then the **Power LED** should remain on. This indicates that communication is established between the WLS-IFC and your computer, and that the device is receiving power.

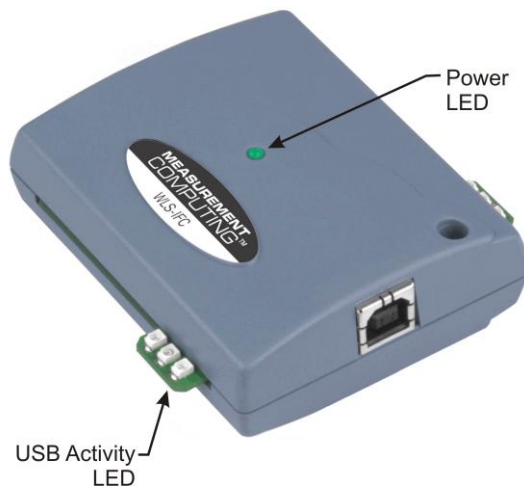

Figure 2. LED locations

If the Power LED turns off

If the Power LED is lit but then turns off, the computer has lost communication with the WLS-IFC. Disconnect the USB cable from the computer and then reconnect it. This should restore communication, and the Power LED should remain *on* after the device is configured.

Configuring the network parameters

The following network parameter options are programmable with InstaCal.

- **Identifier:** Text that identifies the device (optional).
- **PAN (hex):** The personal area network (PAN) ID assigned to the device.

The PAN value is a number used to identify the remote device with which you want to communicate. The WLS-IFC can only communicate with a device whose PAN is set to the same value.

Most users do not need to change the default value assigned to the device. However, you may want to assign a different PAN ID in the following situations:

- You have multiple WLS Series devices, and do not want to allow communication between all of them. Set the PAN ID to the same value on each device that you want to communicate.
- If other WLS Series devices are operating in the vicinity, you can avoid accidental changes to your device settings by changing the default PAN value.

- **CH:** The radio frequency (RF) channel number assigned to the device.

The channel number is used to transmit and receive data over the wireless link. You may want to change the channel number in InstaCal when another WLS Series device is already transmitting on that channel, or when noise is present on the channel.

The table below lists each available channel and its corresponding transmission frequency.

RF Channel	Transmission Frequency (GHz)	RF Channel	Transmission Frequency (GHz)
12	2.410	18	2.440
13	2.415	19	2.445
14	2.420	20	2.450
15	2.425	21	2.455
16	2.430	22	2.460
17	2.435	23	2.465

- **AES Key:** Value used to encrypt data (optional).

AES encryption is disabled by default. Unless you suspect that there are other users of WLS Series devices in the area, there should be no need to enable encryption. However, if you suspect that there are other WLS Series devices in the area, and you need to secure the devices from being accessed by other users, enable AES encryption.

Enabling encryption does NOT secure the device from access through a local USB connection. A remote device configured for encryption can be connected locally through the USB port to access other remote WLS Series devices with the same settings; you may need to physically secure the remote devices to prevent tampering of the of device's network.

Set the PAN ID, RF channel, and AES key to the same value for each device that you want to communicate

Only devices with matching parameter settings for PAN, CH, and AES Key (if set) can communicate with each other.

For information on setting up the network parameters for your WLS-IFC, refer to the "WLS Series" section of the "Temperature Input Boards" chapter in the Universal Library Help.

You only have to set up the network parameters once. The WLS-IFC retains the parameter settings even if you connect to a different computer.

Caution! To satisfy FCC RF exposure requirements for mobile transmitting devices, maintain a separation distance of 20 cm (0.66 feet) or more between the antenna of this device and persons during device operation. To ensure compliance, operations at closer than this distance are not recommended. The antenna used for this transmitter must not be co-located in conjunction with any other antenna or transmitter.

Restoring factory default settings

You can restore the factory default configuration settings with InstaCal.

Functional Details

External components

The WLS-IFC has the following external components, as shown in Figure 3.

- Status LEDs (USB Activity, Transmit, Receive, Received Signal Strength indicators)
- Power LED
- USB connector

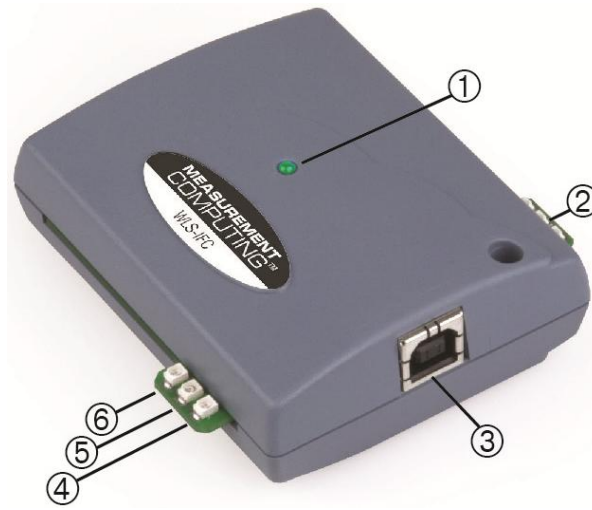

- | | |
|---------------------------------------|--------------------|
| 1 Power LED | 4 USB Activity LED |
| 2 Received Signal Strength (RSS) LEDs | 5 Transmit LED |
| 3 USB connector | 6 Receive LED |

Figure 3. WLS-IFC component locations

Status LEDs

The LEDs indicate the communication status of USB and wireless operations. An LED bar graph indicates the strength of the signal received by the remote device. Refer to the table below for the function of each LED.

LED functions

LED	Function
Power	Steady green – the WLS-IFC is connected to a computer or external USB hub.
	Blinking green – indicates activity over the USB connection.
Received Signal Strength (RSS) indicators	<p>3 green LED bar graph. The LEDs will turn on when receiving a wireless message and stay on for approximately 1 second after the end of the message. They indicate the amount of fade margin present in an active wireless link. Fade margin is defined as the difference between the incoming signal strength and the device's receiver sensitivity.</p> <ul style="list-style-type: none"> ▪ Three LEDs on : Very strong signal (> 30 dB fade margin) ▪ Two LEDs on : Strong signal (> 20 dB fade margin) ▪ One LED on : Moderate signal (> 10 dB fade margin) ▪ No LEDs on: Weak signal (< 10 dB fade margin)
USB activity	Green LED – indicates activity over the USB connection.
Transmit	Yellow LED – indicates transmitting data over the wireless link.
Receive	Red LED – indicates receiving data over the wireless link.

Power LED

The **Power LED** is lit when the WLS-IFC is connected to a computer or external USB hub.

USB connector

The USB connector provides +5V power and communication.

Specifications

All specifications are subject to change without notice.

Typical for 25°C unless otherwise specified.

Specifications in *italic text* are guaranteed by design.

Wireless communications

Table 1. Wireless communications specifications

Parameter	Specification
<i>Communication standard</i>	<i>IEEE 802.15.4, ISM 2.4 GHz frequency band, non-beacon, point-to-point</i>
Range	Indoor/urban: Up to 150 ft (50 m) Outdoor RF line-of-sight: Up to ½ mile (750 m)
Transmit power output	10 mW (10 dBm)
<i>Receiver sensitivity</i>	<i>−100 dBm (1% packet error rate)</i>
<i>RF channels</i>	<i>12 direct sequence channels available, channels 12 – 23 (2.410 – 2.465 GHz) (software selectable)</i>
Addressing	16-bit PAN (personal area network) IDs per channel (software selectable) 64-bit device address
<i>Encryption</i>	<i>128-bit AES (software selectable)</i>

Note 1: Contains FCC ID: OUR-XBEEPRO. The enclosed device complies with Part 15 of the FCC Rules. Operation is subject to the following two conditions: (i.) this device may not cause harmful interference and (ii.) this device must accept any interference received, including interference that may cause undesired operation.

Note 2: Canada: Contains Model XBee-PRO Radio, IC: 4214A-XBEEPRO

Caution! To satisfy FCC RF exposure requirements for mobile transmitting devices, a separation distance of 20 cm or more should be maintained between the antenna of this device and persons during device operation. To ensure compliance, operations at closer than this distance is not recommended. The antenna used for this transmitter must not be co-located in conjunction with any other antenna or transmitter.

Memory

Table 2. Memory specifications

Parameter	Specification
EEPROM	256 bytes USB micro for external application use

Microcontroller

Table 3. Microcontroller specifications

Parameter	Specification
Type	High performance 8-bit RISC microcontroller

USB +5V voltage

Table 4. USB +5V voltage specifications

Parameter	Specification
USB +5V (VBUS) input voltage range	4.75 V min to 5.25 V max

Power

Table 5. Power specifications

Parameter	Specification
Supply current	300 mA max (Note 3)

Note 3: Self-Powered Hub refers to a USB hub with an external power supply. Self-powered hubs allow a connected USB device to draw up to 500 mA. This device may not be used with bus-powered hubs due to the power supply requirements.

Root Port Hubs reside in the PC's USB Host Controller. The USB port(s) on your PC are root port hubs. All externally powered root port hubs (desktop PC's) provide up to 500 mA of current for a USB device. Battery-powered root port hubs provide 100 mA or 500 mA, depending upon the manufacturer. A laptop PC that is not connected to an external power adapter is an example of a battery-powered root port hub.

USB specifications

Table 6. USB specifications

Parameter	Specification
USB device type	USB 2.0 (full-speed)
Device compatibility	USB 1.1, USB 2.0
	Bus powered, 300 mA consumption max
USB cable type	A-B cable, UL type AWM 2725 or equivalent. (min 24 AWG VBUS/GND, min 28 AWG D+/D-)
USB cable length	3 m (9.84 ft) max

Environmental

Table 7. Environmental specifications

Parameter	Specification
Operating temperature range	0 °C to 70 °C
Storage temperature range	-40 to 85 °C
Humidity	0 to 90% non-condensing

Mechanical

Table 8. Mechanical specifications

Parameter	Specification
Dimensions (L × W × H)	79 x 75 × 26.5 mm (3.11 × 2.95 × 1.04 in.)

LED configuration

Table 9. LED configuration

Parameter	Specification
Power	The WLS-IFC is connected to a computer or external USB hub
Received Signal Strength Indicator (RSSI)	3 green LED bar graph. The LEDs will turn on when receiving a wireless message and stay on for approximately 1 second after the end of the message. They indicate the amount of fade margin present in an active wireless link. Fade margin is defined as the difference between the incoming signal strength and the device's receiver sensitivity. <ul style="list-style-type: none"> ■ 3 LEDs on: Very strong signal (> 30 dB fade margin) ■ 2 LEDs on: Strong signal (> 20 dB fade margin) ■ 1 LED on: Moderate signal (> 10 dB fade margin) ■ 0 LEDs on: Weak signal (< 10 dB fade margin)
USB activity	Green LED: activity is detected over the USB connection
Transmit	Yellow LED: data is being transmitted over the wireless link.
Receive	Red LED: data is being received over the wireless link.

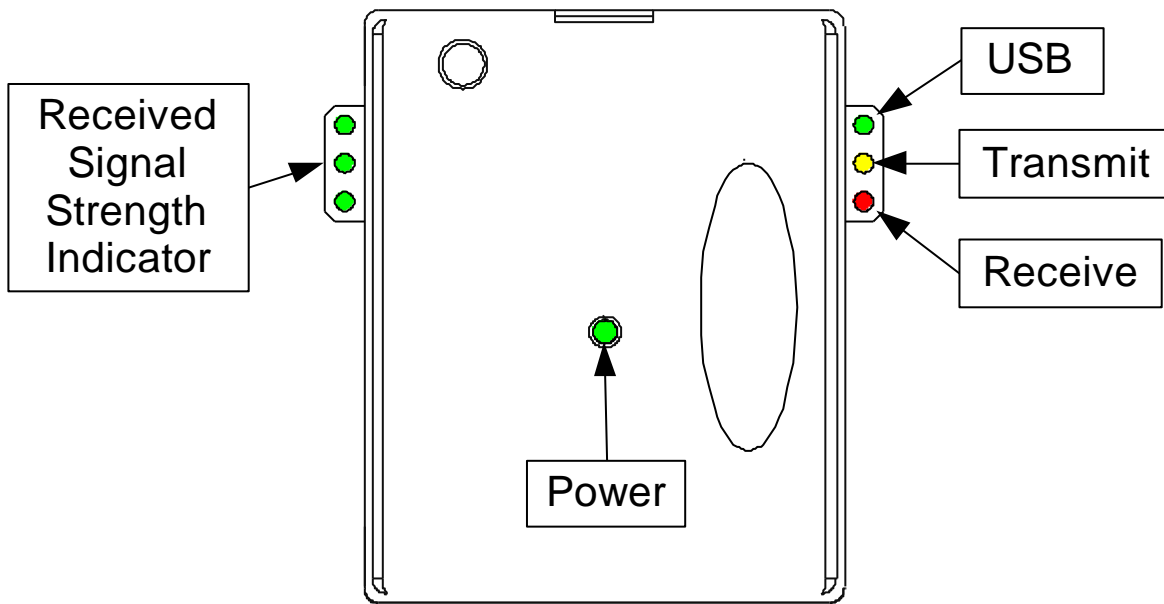

CE Declaration of Conformity

Manufacturer: Measurement Computing Corporation
Address: 10 Commerce Way
Suite 1008
Norton, MA 02766
USA
Category: Electrical equipment for measurement, control and laboratory use.

Measurement Computing Corporation declares under sole responsibility that the product

WLS-IFC

to which this declaration relates is in conformity with the relevant provisions of the following standards or other documents:

EU EMC Directive 89/336/EEC: Electromagnetic Compatibility, EN 61326 (1997) Amendment 1 (1998)

Emissions: Group 1, Class B

- EN 55011 (1990)/CISPR 11: Radiated and Conducted emissions.

Immunity: EN61326, Annex A

- IEC 61000-4-2 (1995): Electrostatic Discharge immunity, Criteria C.
- IEC 61000-4-3 (1995): Radiated Electromagnetic Field immunity Criteria A.
- IEC 61000-4-8 (1994): Power Frequency Magnetic Field immunity Criteria A.

ETSI EN301 489-1 (2004)

IEC 61000-3-2 (2001) Harmonic Current Emissions, IEC 61000-3-3 (2003) Voltage Fluctuations and Flicker

Emissions: Group 1, Class B

- CISPR 22 (2004): Radiated and Conducted Electromagnetic Emissions (USB cable with ferrite suppressor assembly required).
- IEC 61000-3-2 (2001): Harmonic Emissions Class A
- IEC 61000-3-3 (2003): Fluctuations and Flicker

Immunity:

- IEC 61000-4-2 (2001): Electrostatic Discharge immunity, Criteria C.
- IEC 61000-4-3 (2002): Radiated Electromagnetic Field immunity Criteria A.
- IEC 61000-4-4 (2004): Electric fast transient burst immunity Criteria B.
- IEC 61000-4-5: Fast surge immunity Criteria B
- IEC 61000-4-6 (2003): Radio Frequency Common Mode immunity Criteria B*.
- IEC 61000-4-11 (2004): Voltage dips and interrupt immunity Criteria B

* There may be a loss of performance in the presence of an RF electromagnetic disturbance on the input/output ports. Performance loss will be limited to measured temperatures outside of specified accuracy. The transmitter / receiver will continue to operate as specified. Stored data and operating state will be maintained during the disturbance. Operation will recover to within specified limits after the disturbance is removed.

Declaration of Conformity based on tests conducted by Chomerics Test Services, Woburn, MA 01801, USA in November, 2006. Test records are outlined in Chomerics Test Report #EMI4660.06.

We hereby declare that the equipment specified conforms to the above Directives and Standards.



Carl Haapaoja, Director of Quality Assurance

Measurement Computing Corporation
10 Commerce Way
Suite 1008
Norton, Massachusetts 02766
(508) 946-5100
Fax: (508) 946-9500
E-mail: info@mccdaq.com
www.mccdaq.com